

# DACS

inc.

MATERIAL HANDLING

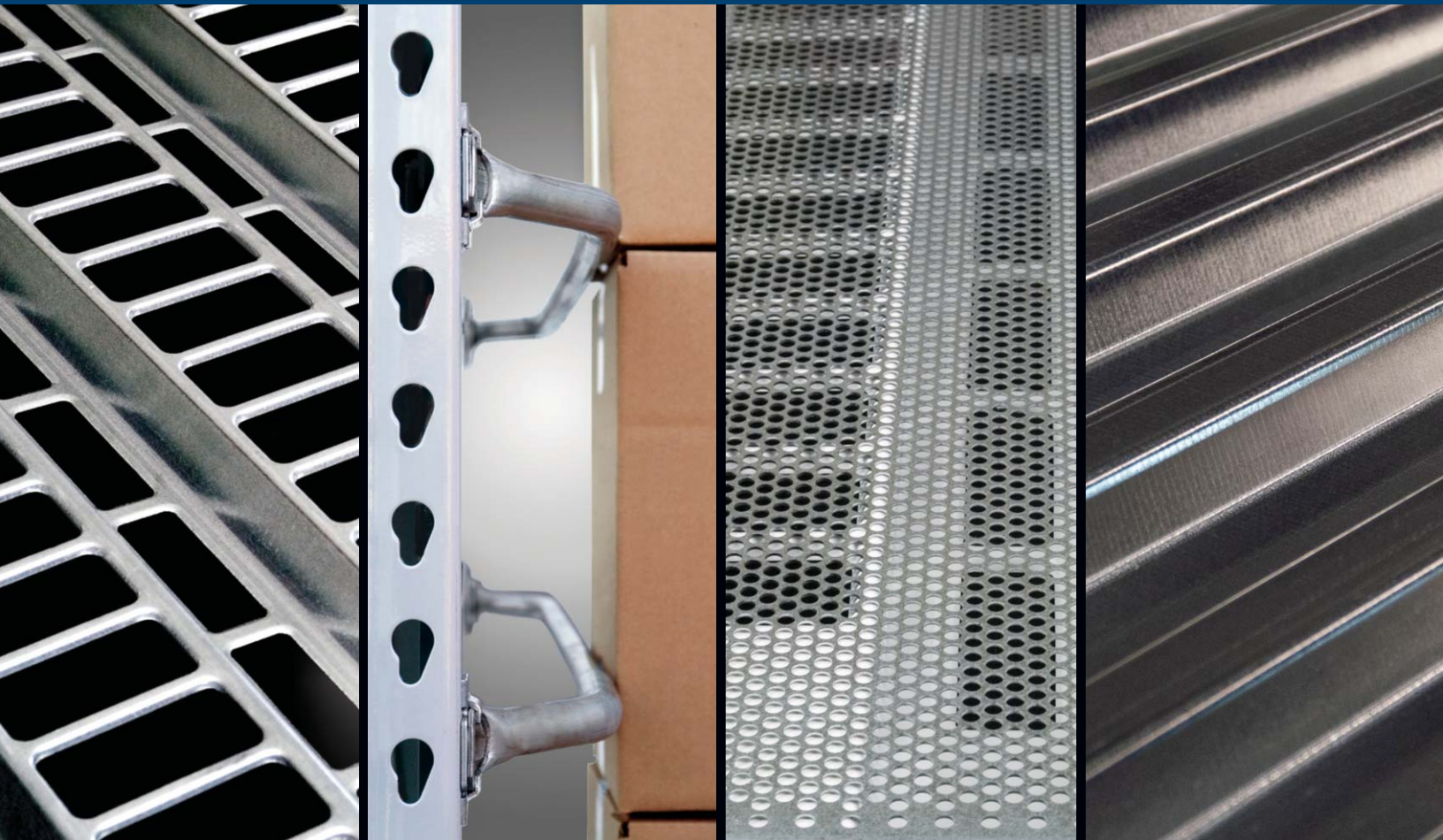

PROVEN SOLUTIONS | ONE SOURCE

PUNCH DECK®

PUNCH DECK® PLUS

FLUEKEEPER®

FIRE BARRIERS

MEZZANINE DECK

SOLID RACK DECK

[www.dacsinc.com](http://www.dacsinc.com)



Sales - Direct & OEM:

**757-337-5111**

e-mail: [sales@dacsinc.com](mailto:sales@dacsinc.com)

Sales - Dealers:

**800-909-4937**

FAX: 800-909-4938

e-mail: [dswanson@dacsinc.com](mailto:dswanson@dacsinc.com)

Corporate Headquarters & Manufacturing:

900 Port Centre Parkway

Portsmouth, VA 23704 USA

+1-757-393-0704 • FAX: +1-757-393-9461

Customer Service: **866-286-6215**

[dacsinc.com](http://dacsinc.com)

[punchdeck.com](http://punchdeck.com)

[fluekeeper.com](http://fluekeeper.com)



## **ABOUT DACS, Inc.**

DACS, inc., founded in 1987, specializes in the manufacture of steel roof deck, floor deck and rack deck.

DACS' original product was solid steel decking, later introducing perforated decking, and then Punch Deck® in 2003. Fluekeeper® was introduced in 2007.

DACS offers one of the largest product lines of steel decking and services in the country. Our company philosophy has always been to offer high quality products at a good value with an emphasis on customer service. Our friendly and experienced staff is always here to help you.

DACS offers engineering services and detailed drawings for every application, and accessories for installation of all our products.

## MATERIAL HANDLING PRODUCTS

### DACS Products Earn Factory Mutual Approval

DACS, Inc. is pleased to announce that its Punch Deck® and Punch Deck® Plus open area rack decking have each been granted an FM Approval\*.

This is the first of its kind for any rack shelving products in the material handling industry.

Samples were laboratory fire tested in accordance with Standard #6914, "Open Shelving for Racks". With this FM Approval, Punch Deck® can be considered equivalent to 70% open area and usable in warehouses with sprinkler protection conforming to FM Global Data Sheet # 8-9, "Storage of Class 1,2,3,4 and Plastic Commodities".

"Industrial and commercial companies around the world rely on products and services that are FM Approved and specification tested to protect their properties from loss. The FM APPROVED mark, which is backed by scientific research and testing, tells customers your product conforms to the highest standards."

- [www.fmglobal.com](http://www.fmglobal.com)



### Contents

Punch Deck® .....	2
Punch Deck® Plus .....	5
FlueKeeper® .....	6
FlueKeeper® HD .....	8
Fire Barriers .....	10
Mezzanine Deck .....	12
Solid Rack Deck .....	13

# PUNCH DECK®

OPEN AREA RACK DECK



## FEATURES & BENEFITS:

- **Fire Protection** - Large openings (50% open area for common rack sizes) allow sprinkler water through to lower levels.
- **Product Friendly** - Punch Deck's smooth top surface reduces product hang-ups that can cause damage.
- **Ergonomically Designed** - Hand stacked boxes slide on and off easily without catching.
- **Uniform Strength** - Punch Deck's repeating corrugations provide uniform strength across the entire shelf and minimize local surface distortions.
- **No Waterfall Edge** - Punch Deck is flush with the top of the step beam allowing for easy labeling and bar coding on the face of the beam.
- **Freight Savings** - Up to 3 times more square footage of Punch Deck can be shipped on a single truck than most other deck products.
- **Attractive Look** - Bright galvanized finish gives your warehouse a sleek clean look that is easy to maintain.
- **Pricing** - Punch Deck is priced competitively with other decking products.
- **Short Lead Times** - Most standard sizes are available for quick shipments. Check with DACS for specific project lead times.



**Punch Deck's open surface area allows sprinkler water through to lower levels.**

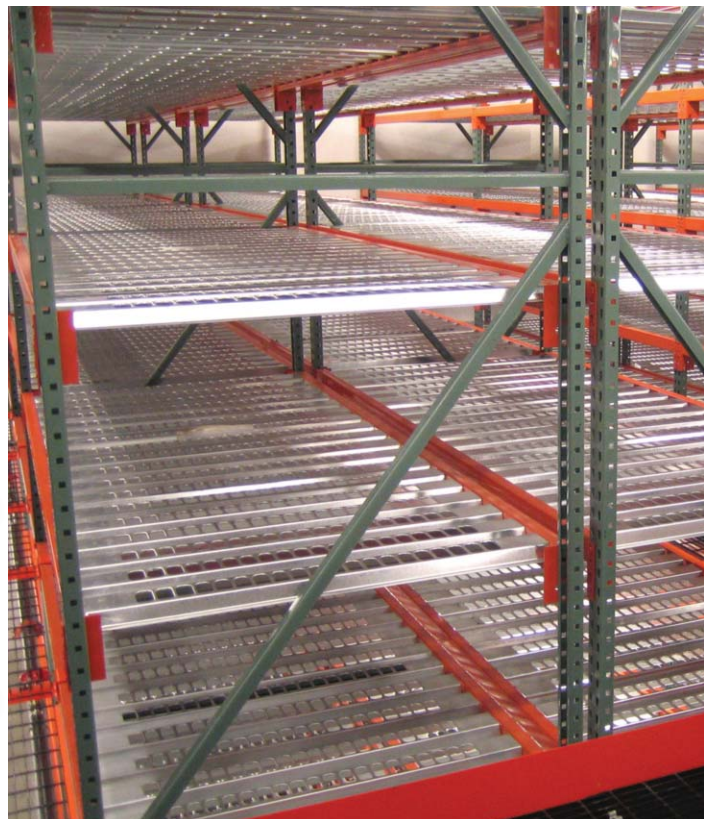
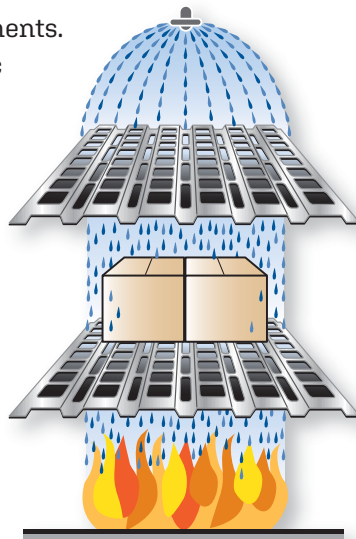

# PUNCH DECK®

OPEN AREA RACK DECK

**Punch Deck® from DACS US Patents #6,401,944 #7,156,243  
Canadian Patent #2,421,323  
Other US & Foreign Patents issued & pending**

## Typical Storage Applications

- Office Records
- Furniture (both pallet & cantilever rack)  
*[See Punch Deck® Plus]*
- Mattresses
- Carpeting and Flooring
- Garments
- Small Boxes
- Rolled Fabrics & Cloth
- Building Components
- Auto Parts
- Bagged Goods

## PUNCH DECK LOAD TABLES

English	Rack Depth - lb/sq. ft.							
	36"	42"	48"	50"	54"	60"	66"	72"
Punch Deck® <b>101</b>	200	135	91	80	64			
Punch Deck® <b>201</b>	225	194	130	115	91	70	50	
Punch Deck® <b>301</b>	250	200	178	158	125	92	70	50

Metric	Rack Depth - kg/sq. m.							
	915mm	1065	1220	1270	1370	1525	1676	1830
Punch Deck® <b>101</b>	978	660	445	391	313			
Punch Deck® <b>201</b>	1100	949	636	562	445	342	245	
Punch Deck® <b>301</b>	1223	978	870	773	611	450	342	245

Capacities are based on uniform distribution, span/180 maximum deflection and 24 KSI maximum steel stress.

## Available Widths

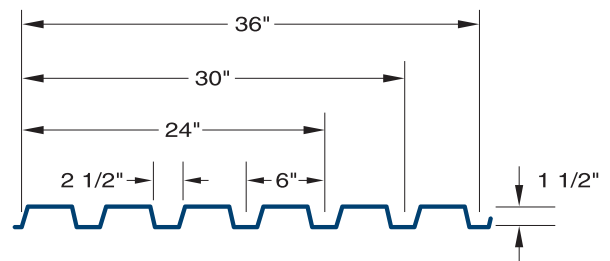

Combine to achieve desired rack shelf coverage.

- Examples: 96" = 2@30" + 1@36"  
 108" = 3@36"  
 144" = 4@36"

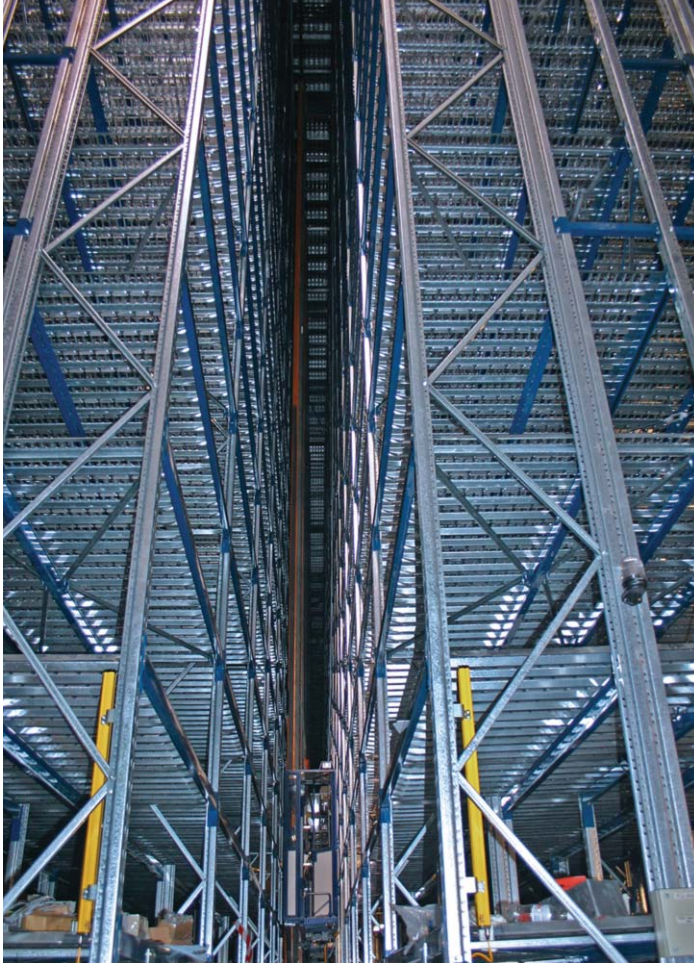

# PUNCH DECK®

OPEN AREA RACK DECK

## PUNCH DECK INSTALLATION RECOMMENDATIONS

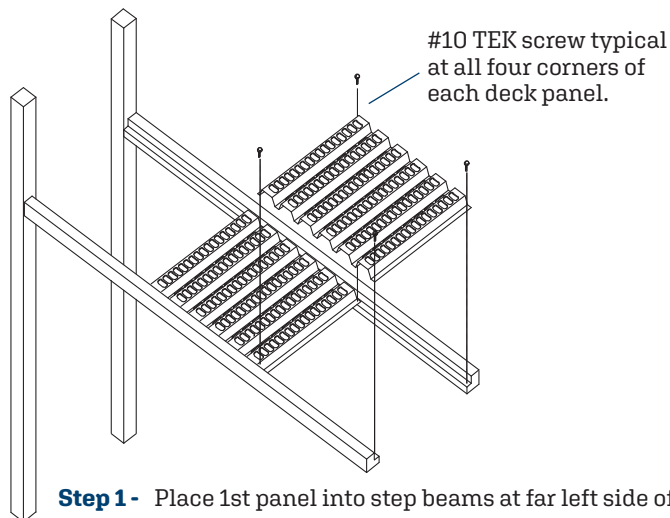

**Step 1 -** Place 1st panel into step beams at far left side of shelf. Position panel so required transverse flue space is maintained between left edge of panel and shelf in adjacent rack bay.

**Step 2 -** Tek screw 2 left hand corners of 1st panel into step beam.

**Step 3 -** Position remaining deck panels into step beam, overlapping as required at joints.

**Step 4 -** Tek screw remaining panels into beam through overlapping joints and at 2 right hand corners.



## ACCESSORIES AND OPTIONS

### Shelf Dividers

Wire dividers for Punch Deck are available in both clip-on and hanging styles. PVC Pipe dividers are ideal for large, bulky items.

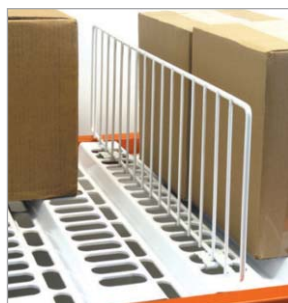

### Low Profile

Low Profile Punch Deck is specifically made to fit beams with a 1" step. (Bulk storage racks, European manufacturers)

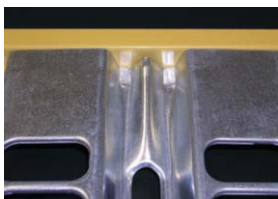

### Wide Span

Punch Deck is available in lengths up to 144" for oversize loads, double-deep racks and carpet racks.

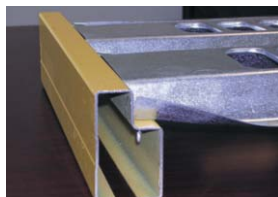

# PUNCH DECK® PLUS



## A Unique Solution for Rack Storage of Furniture in a Sprinklered Warehouse Environment

### PUNCH DECK® PLUS

is offered in a wide range of shelf sizes and load capacities

- Ideal for storage of items with legs or point loads (furniture, equipment with wheels, etc.)
- Easy to install in either pallet rack or cantilever rack
- Galvanized finish is bright and maintenance free
- Available from one source: DACS, Inc.
- Note: Due to the manufacturing process, hole pattern may extend to sheet edge(s)



### Punch Deck® Plus is Open Area Flat Cap OVER Open Area Punch Deck®

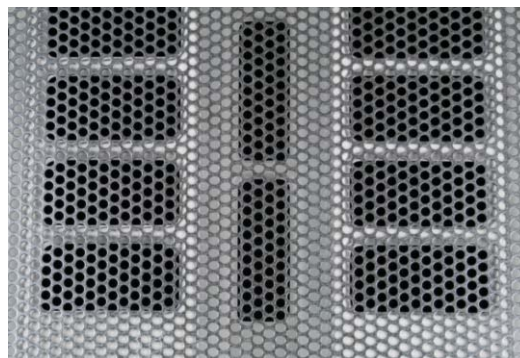

# FlueKeeper®

KEEPS FLUE SPACES OPEN

## A simple, cost effective product to keep stored material out of rack transverse flue spaces

FlueKeeper® from DACS US Patent #7,857,152

### Fluekeeper®

- Allows your sprinkler system to function as designed
- Provides 3" clearance between rack and stored material - Combined with 3" rack post width totals 6" flue space
- Reduces staff "housekeeping" duties
- Satisfies insurance company guidelines and local building inspector criteria (may be required by International Fire Code® 2012 Edition)
- Available for new installations or scheduled retrofit plans
- Spring-loaded Fluekeeper is easy for maintenance personnel to install from the aisle side of the rack - requires no special tools or skills
- Boltless Front & Rear connections make installation possible without removing any items

Original FlueKeepers require 1/2" square holes @ 2" c-c on the side of each rack upright post for End Clips to engage properly (see photo on Installation page). Other hole shapes / sizes, if at 2" c-c, may also be acceptable. Contact your DACS representative with a photo of the holes and rack post for evaluation and approval before ordering.

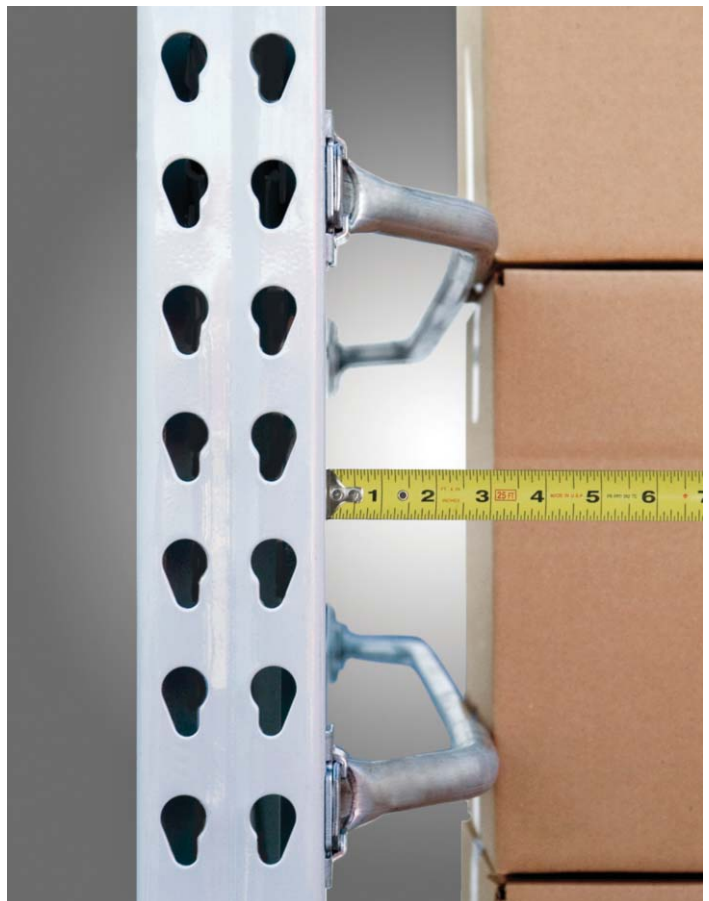
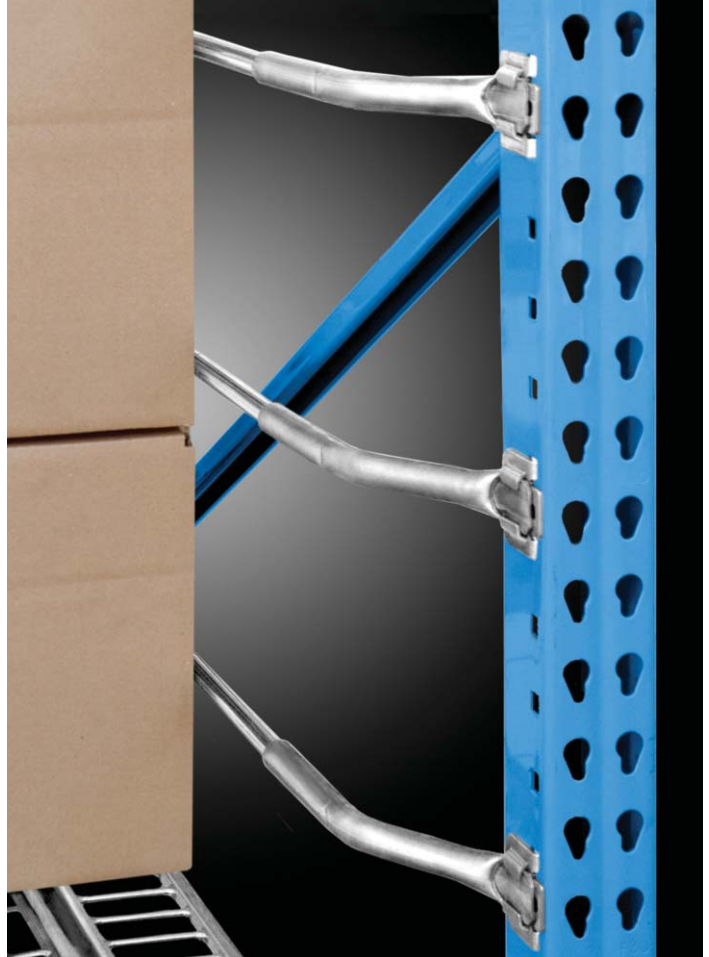





# FlueKeeper®

KEEPS FLUE SPACES OPEN

## FlueKeeper components and installation

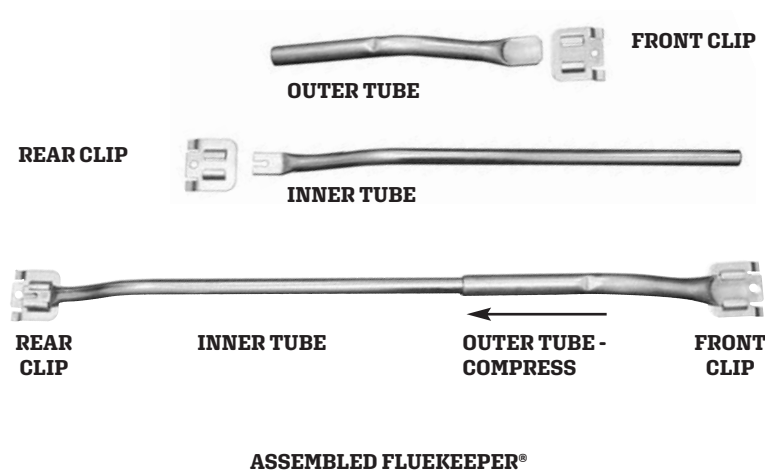

## Fluekeeper® Fixed Length



- For rack posts that do not accept Spring-Loaded version clips
- Fixed-length Fluekeeper® installs easily with TEK® screws

# FlueKeeper® HD

**(HEAVY DUTY): A simple, cost effective product to keep palletized material out of rack transverse flue spaces**

FlueKeeper® HD from DACS US Patent #7,857,152

## Fluekeeper® HD

- Allows your sprinkler system to function as designed
- Provides 3" transverse flue space on each side of rack post (6" total)
- Heavy duty tube member designed for up to 48" frames (deeper by special request)
- Boltless front & rear beam type connections make for easy installation, without any special tools or skills.

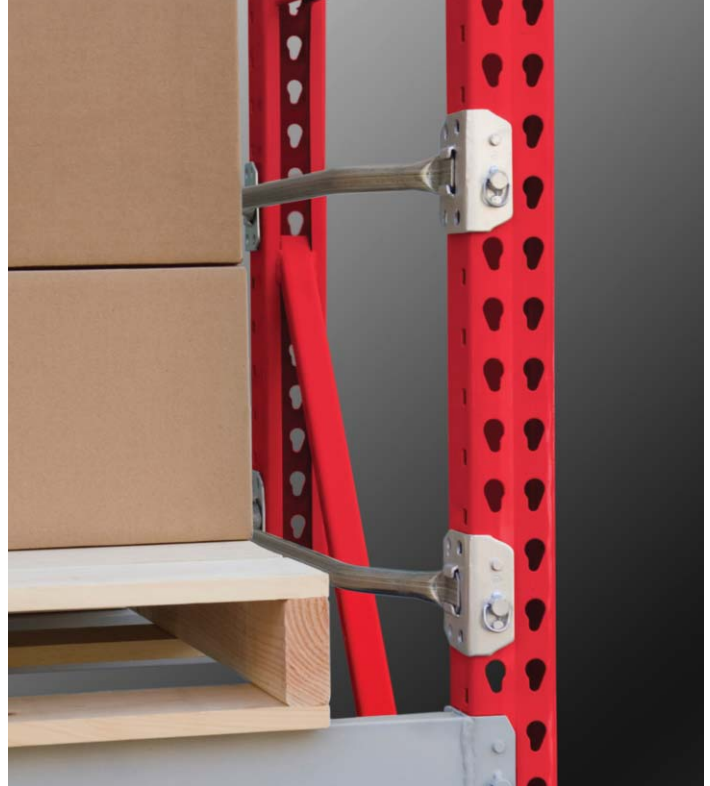

## Installation

- Step 1:** Install rear connector into rear post, engaging safety lock.
- Step 2:** Insert tube into rear connector.
- Step 3:** Insert tube into front connector, install front connector into front post, engaging safety lock.



# FlueKeeper® HD

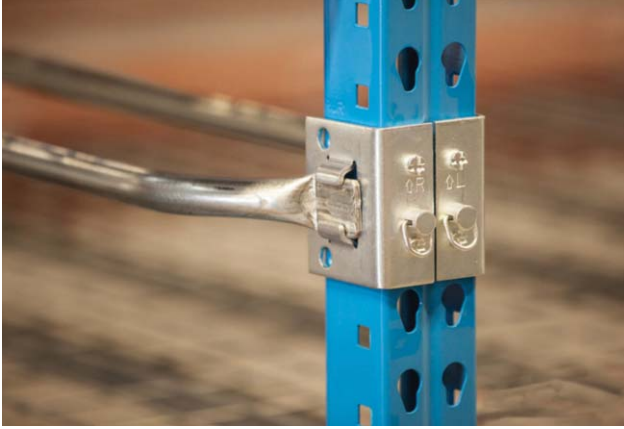

## Fluekeeper® HD

- Can be used at pallet and/or product elevations
- Satisfies insurance company guidelines and local building inspector criteria (may be required by International Fire Code® 2012 Edition)
- Connectors available for all major rack brands
- Suitable for new installations or scheduled retrofit programs



## Fluekeeper® HD | STRUCTURAL

- Allows your sprinkler system to function as designed
- Provides 3" transverse flue space on each side of rack post (6" total)
- Heavy duty tube member designed for up to 48" frames (deeper by special request)
- Bolted front & rear connections
- Can be used at pallet and/or product elevations
- Connectors available for all major structural rack brands
- Hardware provided for single or double post uprights

# Fire Barriers

**Today's warehouse fire protection systems include more than just pipes and sprinklers.**

When the products being stored include highly flammable items such as plastics, aerosols, liquors or oils, fire barriers may be required inside the racking structure.

Solid steel rack decking and flat sheet accessories from DACS make effective fire or heat barriers in warehouse environments. In a fire event, the barriers assist in capturing heat and thus activating in-rack sprinklers or helping to contain the spread of flames down a row of pallet racking.

DACS provides design and manufacturing of both horizontal and vertical steel fire barriers for all rack types. They are available in a variety of gauges, finishes and profiles.

Also available are flanged and flat caps to cover both longitudinal and transverse flue spaces.

Types and profiles are listed on the next page.

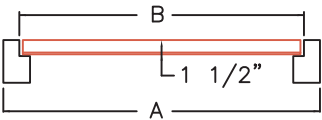
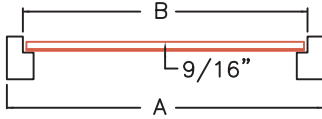
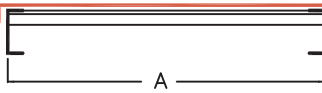
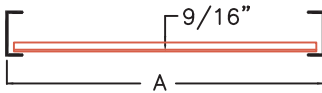
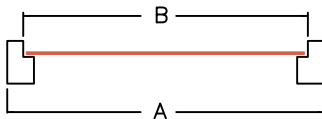
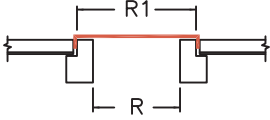
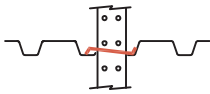
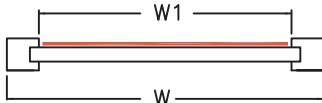
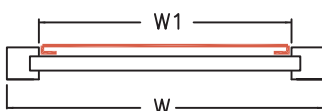
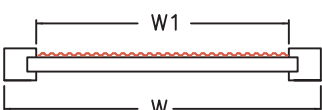
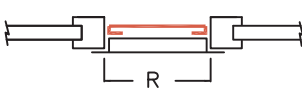

# Fire Barriers Types

Plane	Type	Design	Product	Notes
Horizontal	<b>H1</b>		B-Deck	Load bearing
Horizontal	<b>H2</b>		S-Deck	Non load bearing
Horizontal	<b>H3</b>		Sheet	Flanged front & rear
Horizontal	<b>H4</b>		S-Deck	Sits on channel flanges
Horizontal	<b>H5</b>		Sheet With Stiffeners	Non load bearing
Horizontal	<b>F1</b>		Sheet	Cap over back to back longitudinal flue space
Horizontal	<b>F2</b>		Sheet	Cap over frame transverse flue space
Vertical	<b>V1</b>		Sheet	
Vertical	<b>V2</b>		Sheet	Hemmed long edges
Vertical	<b>V3</b>		S-deck	
Vertical	<b>V4a</b>		Sheet	Hemmed long edges

Notes: Thickness of all products will be 22 gauge (min.) as required by fire codes. Contact DACS for fastening details.

v3 1122

# Mezzanine Deck

Mezzanine Deck from DACS is the ideal flooring material for mezzanines, catwalks and overhead aisle ways. Our mezzanine decking is available with a bright white paint finish or a galvanized finish on the underside. When lights are installed under the structure, the result is a bright and highly reflective surface.

Corrugated steel mezzanine decking can be cut to any length required, and is available in 36", 30" and 24" widths.

## Mezzanine Decking 1-1/2" High Box Rib Decking

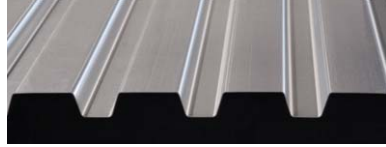

Capacities in Pounds  
per Square Foot

OPEN SPAN	4 FT.	4.5 FT.	5 FT.	5.5 FT.	6 FT.	6.5 FT.
<b>SINGLE SPAN DECKING</b>						
22 GAUGE "B" BOX RIB	155	122	92	72	58	47
20 GAUGE "B" BOX RIB	189	150	114	88	70	58
18 GAUGE "B" BOX RIB	256	202	159	122	96	78
<b>DOUBLE SPAN DECKING (1 PCS. OF DECKING COVERING 2 OPEN AREAS)</b>						
22 GAUGE "B" BOX RIB	162	128	104	86	72	61
20 GAUGE "B" BOX RIB	200	158	128	106	89	76
18 GAUGE "B" BOX RIB	262	207	168	139	116	99
<b>TRIPLE SPAN DECKING (1 PCS. OF DECKING COVERING 3 OR MORE OPEN AREAS)</b>						
22 GAUGE "B" BOX RIB	203	160	130	109	89	72
20 GAUGE "B" BOX RIB	250	197	160	132	111	89
18 GAUGE "B" BOX RIB	328	259	210	173	146	123

## Mezzanine Decking 3" High "N" Deck for Extra Long Span Conditions

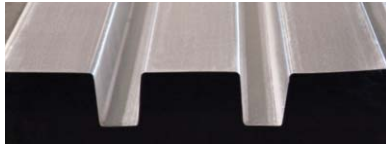

Capacities in Pounds  
per Square Foot

OPEN SPAN	7.5 FT.	8 FT.	8.5 FT.	9 FT.	9.5 FT.	10 FT.
<b>SINGLE SPAN DECKING</b>						
22 GAUGE "N" BOX RIB	90	79	70	62	56	50
20 GAUGE "N" BOX RIB	117	102	91	81	72	54
18 GAUGE "B" BOX RIB	168	148	131	117	103	90
<b>DOUBLE SPAN DECKING (1 PCS. OF DECKING COVERING 2 OPEN AREAS)</b>						
22 GAUGE "N" BOX RIB	110	97	85	76	68	62
20 GAUGE "N" BOX RIB	137	120	107	95	85	77
18 GAUGE "N" BOX RIB	185	163	144	129	115	104
<b>TRIPLE SPAN DECKING (1 PCS. OF DECKING COVERING 3 OR MORE OPEN AREAS)</b>						
22 GAUGE "N" BOX RIB	137	121	107	95	85	77
20 GAUGE "N" BOX RIB	171	151	133	119	107	96
18 GAUGE "N" BOX RIB	232	204	180	161	144	130

PLEASE NOTE: Loads are based on uniform distribution in pounds per square foot based on stress of 20,000 PSI. If you have specific deflection criteria, please call.

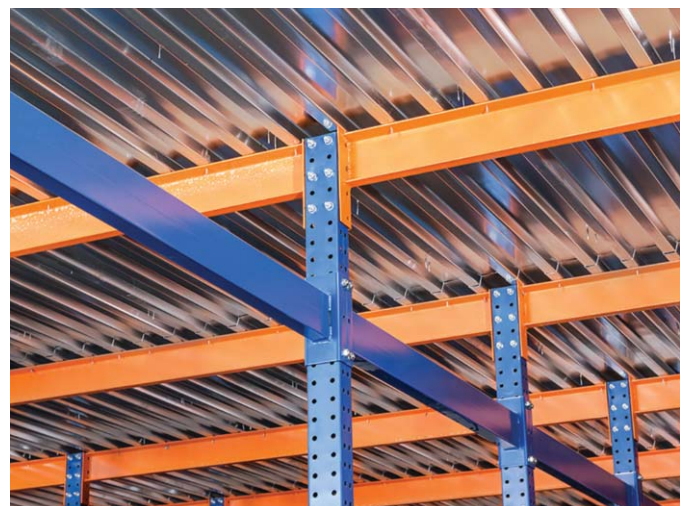
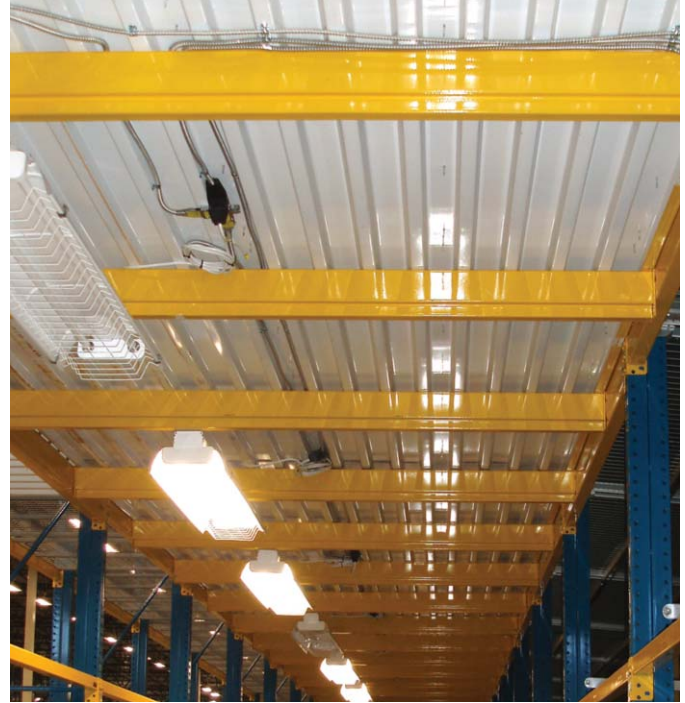

# Solid Rack Deck

Solid Corrugated Steel Rack Decking from DACS has many applications including:

- Record Storage
- Carpet & Fabric Storage
- Palletized Loads
- Heavy Duty Die Storage

DACS solid rack deck sits flush with the top surface of the pallet rack beam, creating a smooth flat surface for product to easily slide on and off. Sizes are available to fit any standard rack. It is also used attached to the floor for elevated bottom-level storage.

Corrugated steel decking is stronger than wood and less expensive than both wood and wire. It provides a seamless, solid support from the front all the way to the back of the rack bay for even the longest stored items.

DACS solid rack decking is perfect for use in cantilever rack as well. It is often used to provide a stacking surface between the cantilever arms for storage of everything from lumber to furniture to fabric.

Solid rack decking is available with a galvanized or painted finish. Please call regarding stainless steel.

## Box Rib (B deck) - 1-1/2" high

Designed for Heavy Loading Requirements

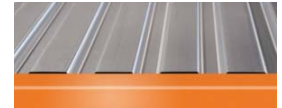

Capacities in Pounds per Square Foot

RACK DEPTH:	36"	42"	44"	48"	54"	60"
22 GAUGE	397	283	256	210	147	108
20 GAUGE	490	350	316	262	186	136
18 GAUGE	666	475	430	356	262	190

## Flat Rib (F deck) - 1-1/2" high

Designed to Provide Larger Top Surface Area

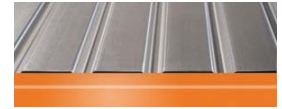

Capacities in Pounds per Square Foot

RACK DEPTH:	36"	42"	44"	48"	54"	60"
22 GAUGE	290	207	187	155	121	93
20 GAUGE	358	255	231	191	149	116
18 GAUGE	490	350	316	262	204	162

## Narrow Rib (A deck) - 1-1/2" high

Designed to Provide 75% Top Surface Area



Capacities in Pounds per Square Foot

RACK DEPTH:	36"	42"	44"	48"	54"	60"
22 GAUGE	286	204	184	153	119	95
20 GAUGE	347	247	224	185	144	115
18 GAUGE	457	327	295	245	190	152

## Sturdy Rib (S deck) - 9/16" high

Designed for Economical Rack and Shelving Needs

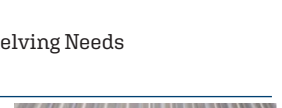

Capacities in Pounds per Square Foot

RACK DEPTH:	24"	28"	32"	36"
26 GAUGE	114	72	48	34
24 GAUGE	155	98	65	46
22 GAUGE	188	118	79	55

PLEASE NOTE: Loads are based on uniform distribution in pounds per square foot based on stress of 20,000 PSI. If you have specific deflection criteria, please call.



# DACS inc.

## MATERIAL HANDLING

Sales - Direct & OEM:

**757-337-5111**

e-mail: [sales@dacsinc.com](mailto:sales@dacsinc.com)

Sales - Dealers:

**800-909-4937**

FAX: 800-909-4938

e-mail: [dswanson@dacsinc.com](mailto:dswanson@dacsinc.com)

900 Port Centre Parkway, Portsmouth, VA 23704 USA

+1-757-393-0704 • FAX: +1-757-393-9461

Customer Service: **866-286-6215**



PROVEN SOLUTIONS | ONE SOURCE

© 2023 DACS, INC.

[www.dacsinc.com](http://www.dacsinc.com)